

'Mat' Harvesting of Forages - Intensive Conditioning to Increase Feeding Value

Richard G. Koegel¹
Richard J. Straub²

ABSTRACT

Intensive or severe conditioning of forage crops (sometimes called "maceration") greatly reduces the field-drying time required to reach moisture levels suitable for harvesting as hay or as silage. In addition, severely conditioning alfalfa has been shown to increase alfalfa digestibility by 10% or more. Because of the many small fragments resulting from intensive conditioning, the forage has been pressed into a continuous cohesive strip called a "forage mat". Prototype machines which (1) mow, (2) macerate, (3) form "mats" and (4) place them on the stubble have been built by research and development groups.

Key Words: alfalfa, maceration, drying rate, digestibility, feeding trials

INTRODUCTION

Intensive forage conditioning refers to a degree of mechanical conditioning more severe than that achieved by conventional mower-conditioners. Extreme conditioning is sometimes called "maceration". Because extreme conditioning creates many small plant fragments which tend to be lost when the forage is placed on the stubble to dry, it has been found advantageous to press the forage into a thin, continuous, cohesive strip called "forage mats."

Intensive conditioning yields at least two advantages:

(1) an accelerated rate of drying; up to three times as fast as conventionally conditioned forage under good drying conditions, and (2) improved forage utilization; in particular increased energy derived from the forage fiber (~10% increase).

Equipment and Process

Forage mats are made by a machine which substitutes for the conventional mower-conditioner. This machine carries out four functions: (1) mows, (2) macerates (severely conditions), (3) rolls the forage into thin, continuous, cohesive mats, and (4) places the mats onto the stubble for drying (Fig. 1).

¹Corresponding Author: Richard G. Koegel, Research Agricultural Engineer, USDA-Agricultural Research Services, U.S. Dairy Forage Research Center, 1925 Linden Drive West, University of Wisconsin, Madison 53706

²Professor of Agricultural Engineering, University of Wisconsin - Madison.

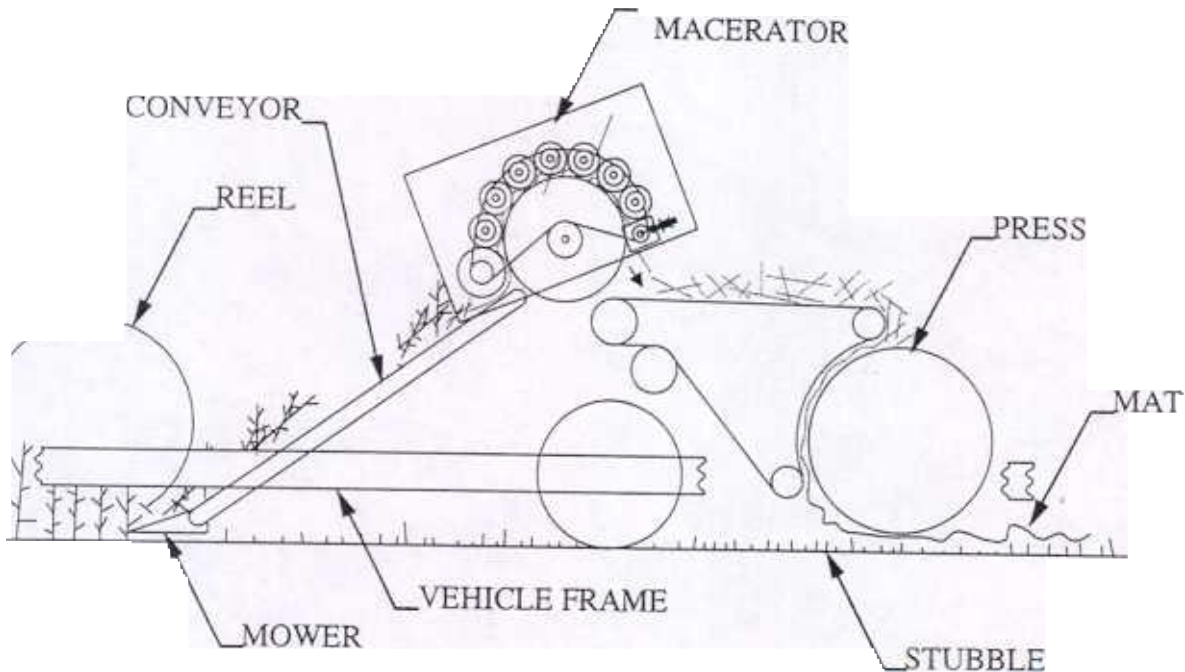

Figure 1. Schematic of the Original Wisconsin Prototype Mat Machine

In order to achieve near-optimum drying rates, the mats should be dense and not much thicker than 3/8 inch. For heavy crops, such as first cutting alfalfa, this results in the mats being spread over about 70% of the cut area. For lighter subsequent cuttings, mats would cover 50% or less of the cut area.

Figure 2 (Shinners et al, 1987) compares field-drying of alfalfa mata with that of conventionally conditioned material under very good drying conditions. In this case the mat reached the target moisture content of 20% in less than five hours. In the case of silage-making, a suitable moisture content was reached in about two hours. In either case, the mat process allows the alfalfa to be mowed and harvested during the same daylight period. As drying conditions become less favorable, the differences in drying rates between the mats and conventional material become less dramatic, and under extremely bad conditions there may be little difference.

Because stems are generally split into many slender ribbons or fibers, and the leaf and stem materials are homogenized, they tend to dry at a common rate. This largely eliminates the problem of leaves over-drying and shattering while waiting for stems to dry adequately. Small plant fragments are generally "pasted" within the mat structure by the drying plant juice. Therefore, with proper equipment, harvesting losses can be kept to a very modest level.

The severe conditioning or maceration has been accomplished successfully by two different mechanisms to date. The first system (Fig. 3) consists of passing the forage between multiple pairs of rollers with roughened or serrated surfaces with the opposing surfaces traveling at

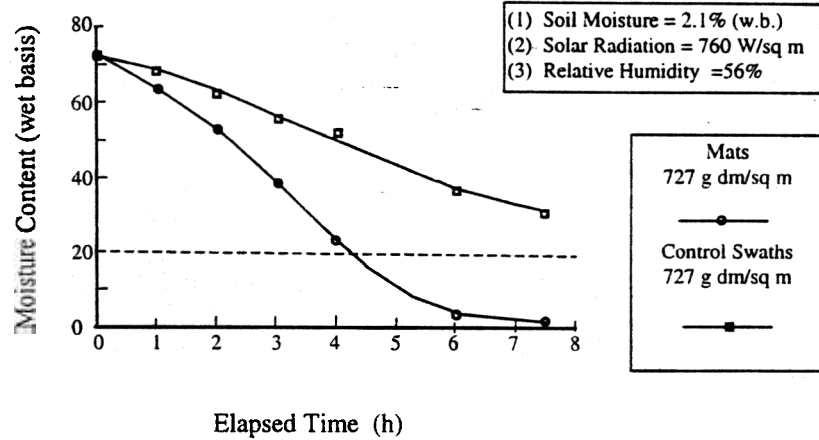

Figure 2. A Comparison of Drying Rates for Mat-Processed and conventionally Conditioned Alfalfa.

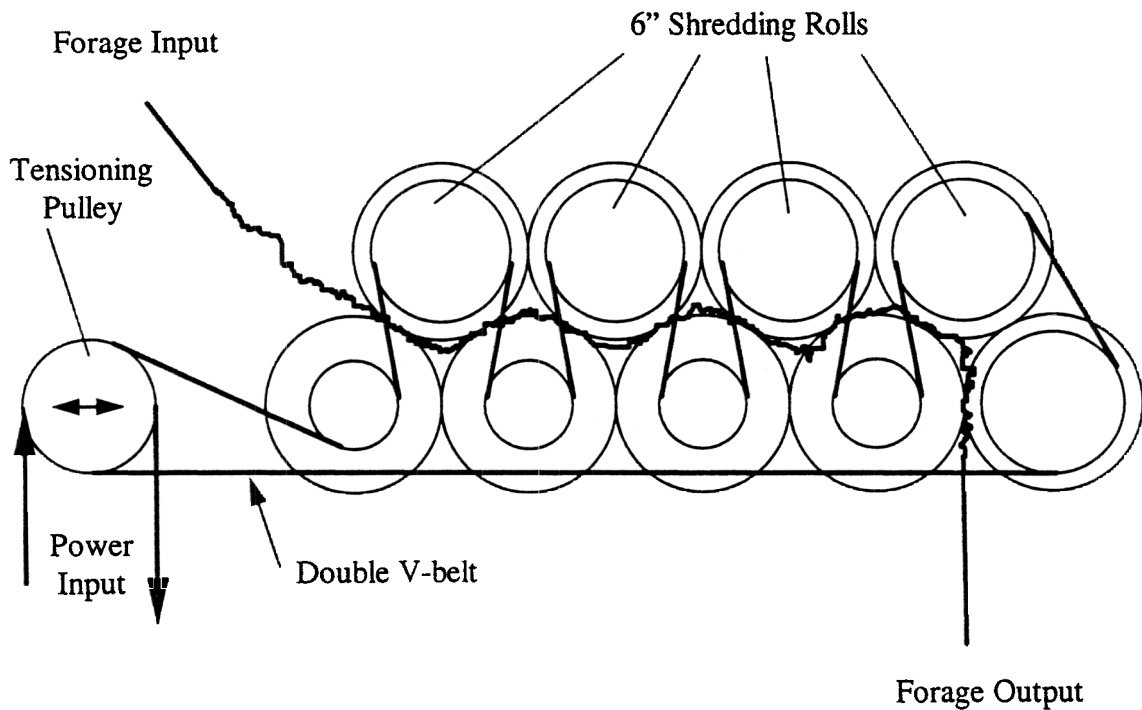
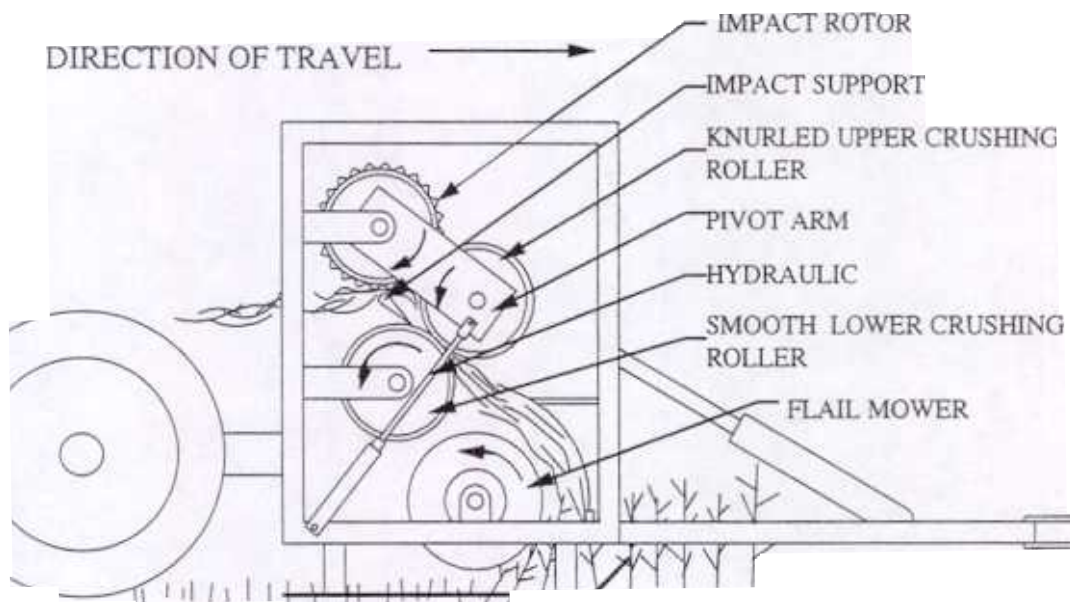

Figure 3. Schematic of Roughened - Roll Macerator



Mats have been formed and pressed in a variety of ways generally involving drums, rollers, and carrier belts (Fig. 5). The mat press, regardless of its configuration, should fulfill several requirements: (1) its surface speed must match ground speed to allow mats to be laid intact onto the stubble, (2) mats should be supported as close to the stubble as possible, since their wet strength is not great, (3) the mats should be held under pressure for as long as practical to improve their consolidation and strength, and (4) the pressing rolls or surfaces should provide grooves or depressions to allow the plant juice a location for momentary “escape” while the fibrous material is being forced together. As soon as pressure is released from the mat, any free juice is instantly reabsorbed. There is a common misconception that the forage mat process removes juice from the plant material much like the wringer rolls on a washing machine. This is

not the case; all plant juice remains with the mat. Fast drying is the result of the juice being exposed to the evaporative process.

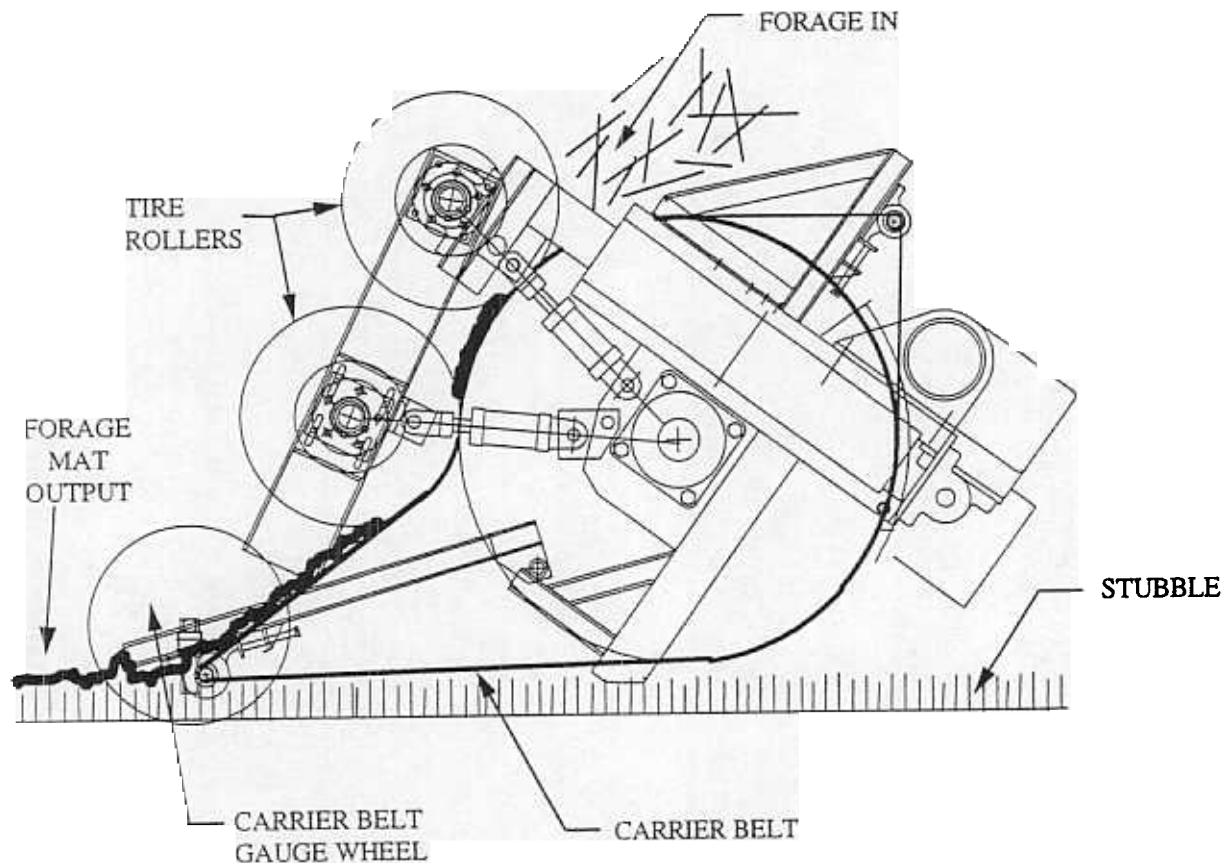

Figure 5. Press for Forming Macerated Forage Mats

Since mat thickness is an important factor in determining drying rate, it is necessary that mat thickness be kept reasonably uniform to eliminate damp spots, especially when drying for hay. This requires that the press be fed as uniformly as possible from the macerator. If the forage is being ensiled, then mat uniformity is of less importance as long as the final average moisture content is suitable.

Feeding Trials

A number of feeding trials have been conducted over a period of years comparing animal utilization of severely conditioned alfalfa with that of conventionally harvested material. The results have consistently shown that animals are able to utilize the severely conditioned material to a greater extent. The explanation given for this phenomenon is that the more severely conditioned plant material has more exposed surface area and many more damaged sites where the rumen microorganisms can penetrate and colonize. Microphotographs have borne this out showing many more sites with large colonies of microorganisms.

Early feeding trials were carried out with sheep and goats, because of the relatively small amounts of severely conditioned forage available. Table 1 gives the results of two feeding trials with sheep (Koegel et al, 1992) comparing mat-harvested alfalfa hay with conventionally harvested material. Dry matter intake was increased by 6.1% and 4.9 % and NDF digestibility was increased by 12.8% and 17.8%. A trial with lactating goats comparing the same materials (Table 2) showed the following increases for mat-harvested material: dry matter intake, 5.7%, milk production 12.1%, and protein production 5.3%. Table 3 shows the results of two later sheep feeding trials comparing mat-harvested and conventional alfalfa silage (Koegel et al, 1992). In the first trial the mat-harvested material showed an improvement in dry matter digestibility of 15.9% and in the second trial it showed an advantage in weight gain per unit feed of 18.8%.

Table 1. Digestibility trials with alfalfa hay on sheep.

	Control	Mat	% Difference
Trail 1. Eight wethers for 12 weeks			
Dry matter intake, kg/d	1.15 ^b	1.22 ^a	6.1
Apparent NDF digestibility, %	43.0 ^d	48.5 ^c	12.8
Trial 2. Four wethers for 4 weeks			
Dry matter intake, kg/d	1.22	1.28	4.9
Apparent NDF digestibility, %	35.3 ^d	41.6 ^c	17.8

^{ab}Means in rows with different superscripts differ ($P < 0.10$).

^{cd}Means in rows with different superscripts differ ($P < 0.05$).

Table 2. Digestibility trials with lactating goats fed on 60% alfalfa hay and 40% grain (10 goats for 4.5 weeks.)

	Control	Mat	% Difference
Dry matter intake, kg/d	2.44 ^b	2.58 ^a	5.7
Milk, 4% fat corrected, kg/d	3.3 ^b	3.7 ^a	12.1
Protein, kg/d	0.103 ^b	0.108 ^a	4.9

^{ab}Means in rows with different superscripts differ ($P < 0.10$)

Table 3. Digestibility trials with alfalfa silage fed ad libitum, to sheep.

	Control	Mat	% Difference
Trail 1. Eight sheep for 6 weeks (digestion stalls)			
Ave dry matter digestibility, %	59.68	69.18	15.9
Daily dry matter intake % body weight	3.42 ^a	4.49 ^b	31.3
Trial 2. Twenty-six sheep for 2 weeks (pen of 13)			
Daily dry matter intake, % body weight	2.65	3.02	14.0
Ave weight gain, kg	2.98 ^c	3.68 ^b	23.5
kg gain/kg dry matter	0.149	0.177	18.

^{ab}Means in rows with different superscripts differ ($P < 0.10$).

In the first feeding trial done with lactating cows, (Koegel et al, 1992) no milk production advantage was found (Table 4). However, the cattle fed with the mat-harvested alfalfa silage had an increase in body weight more than four times that of the control group. Taking into account milk produced, weight gain, and energy for maintenance, it was calculated that the cattle had derived about 10.8% more energy from the mat-harvested silage than from the conventional silage. Based on this and other results, it was believed that mat-harvested forage could be used to replace some of the grain in dairy rations while maintaining production at or near the genetic potential of the cattle.

Table 4. Digestibility trial with lactating cows fed 65% alfalfa silage and 35% concentrate (12 cows for 8 weeks).

	Control	Mat	% Difference
Milk production, kg/d	24.5	24.2	n.s.d.
Fat, % 3.7	3.5	n.s.d.	
Body weight increase, kg/d	0.08 ^a	0.44 ^b	450
Dry matter intake, kg/d	19.9	19.6	n.s.d.
Calculated energy from forage, MJ/kg	4.61	5.11	10.8

^{ab}Means in rows with different superscripts differ ($P < 0.01$).

A recent feeding trial appears to substantiate this belief (Mertens, 1995). In this trial two groups of twelve cattle each were selected for equal production. Prior to the trial both groups were fed a relatively high grain:forage ration typical of production practice. At the beginning of the trial both groups were gradually switched to rations higher in forage and lower in grain. As can be seen in Figure 6, after a brief adjustment period, the cattle receiving mat-silage were able to maintain approximately the level of production they had on the previous higher grain ration and to out-produce the cattle on the conventional silage ration by 7-8%.

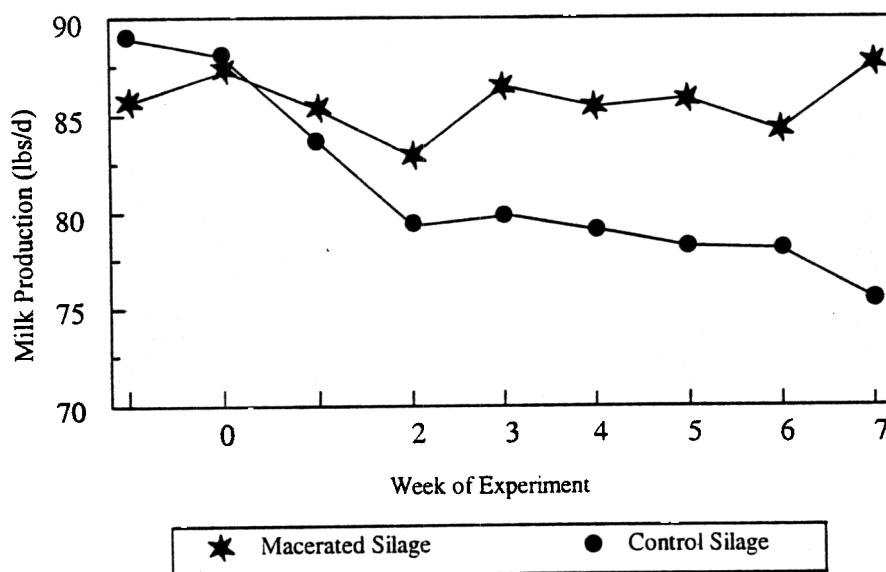

Figure 6. 1995 Lactation Study Comparing Macerated and Conventionally Conditioned Alfalfa Silage.

In addition to showing consistent advantages in the energy derived from mat-harvested forages, feeding trials have also showed indications of increases in the level of bypass protein (that protein which escapes the rumen undegraded allowing more efficient utilization in the gut) for mat-harvested forages relative to conventional forages. Yang et al (1993) showed an increase of estimated bypass protein of 21% for mat-harvested alfalfa hay relative to conventionally harvested alfalfa hay. Mertens (1993) found a decrease in rumen ammonia for mat-harvested alfalfa hay and silage relative to conventionally harvested material of 23.9% indicating less ruminal protein breakdown for the mat harvested alfalfa.

Harvesting and Storage

As stated earlier, intensively conditioned forages may be stored and fed either as silage or as dry hay. In either case the first step is to pick up the forage from the stubble. In early trials, it appeared that the conventional drum and tine pick-up tended to break up the mats leading to excessive losses. As a result, a belt and tine pick-up was developed which could be used with either a baler or a forage harvester (Fig. 7). This pick-up was similar to those used with combines to pick up swathed grain. Other workers have considered a drum and time pick-up satisfactory, however. More recently a third type of pick-up has been used for picking up mats. This consists of a rapidly rotating rotor with plastic paddles enclosed by a suitable housing. In addition to the paddles impacting and throwing pieces of the mats, they create an air stream which appears to entrain small fragments vacuum cleaner fashion. A pick-up unit of this type was made by replacing the rotor of a flail chopper with a plastic paddle rotor. This unit retained the cross auger and blower (which also did minimal chopping), so that it could be used to pick up and convey the mats to a trailed wagon for subsequent ensiling.

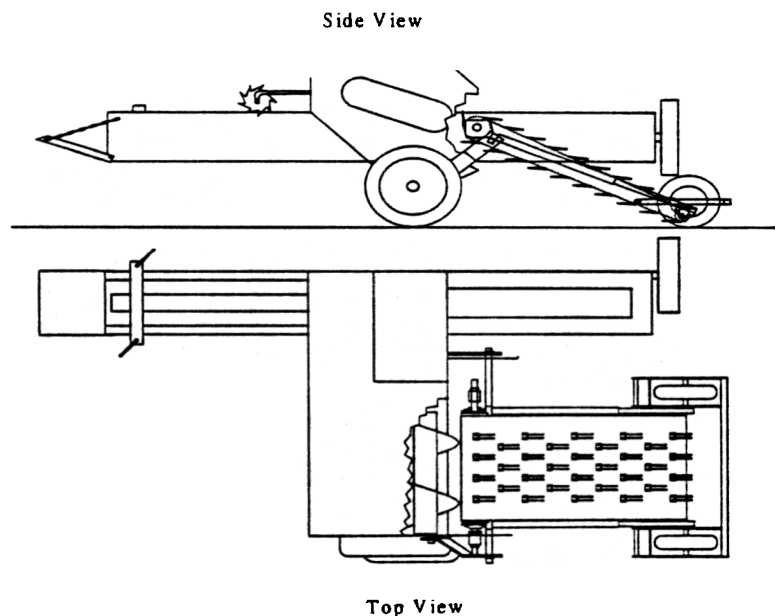

Figure 7: Belt-and-Time Pick-up for Forage Mats Mounted on Conventional Small Rectangular Baler.

Because of the very compliant nature of severely conditioned or macerated alfalfa, it was found that when ensiling good packing was obtained without chopping (Shinners et al, 1988). However, to improve handling characteristics into and out of the silo and in TMR mixers, some minimal chopping might be considered desirable. Muck et al (1989) found that in ensiled alfalfa, mat-processed material fermented about twice as rapidly as conventionally processed material, reaching final pH in half the time or less.

The compliant nature of mat-processed alfalfa is also apparent when baling. This has allowed 25%-35% more dry matter to be packed into a bale of a given size. The authors' experience has been limited to small rectangular bales, however.

If rained on, forage mats retain their integrity. However, leaching loss (loss of soluble carbohydrates) may be 3-5 times that of conventionally conditioned material. The probability of being rained on, however, is minimized by the short dry-down time.

The upper surface of forage mats tend to bleach while drying in sunlight. Because the mats are dense, only a small amount of material in the uppermost layer is affected. After the mats have been broken up in the harvesting process, bleaching is generally not perceptible.

Equipment Development

European manufacturers have taken the lead in development of equipment for intensive conditioning. The Deutz-Fahr Company of Germany has had working prototypes for about five years. These are self-propelled machines having many of the features of the original Wisconsin machine. While farm publications have printed dates for the commercial debut of this machine as early as 1996, this appears doubtful. Two companies, the Greenland Group of the Netherlands and Krone of Germany have introduced intensive forage conditioning machines to the market. While these machines condition more intensively than conventional machines, they do not condition as intensively as the work reported in the U.S. and they do not form the forage into a cohesive body like a mat. They appear to be adapted to grass only and the production of silage only. Since conditioning is less severe than the work reported here, it is not known whether there would be any improvement in digestibility. None has been claimed to date.

Two Canadian research groups are active in the development of equipment for intensive conditioning. They are Agriculture Canada at the University of Laval at Quebec and the Prairie Agricultural Machinery Institute near Winnipeg. The former group has developed several machines including both trailed and self-propelled units and has carried out feeding trials showing improved performance of intensively conditioned forage.

On-Going Research

It is estimated that work on intensive conditioning is ongoing at least ten different locations around the world. Because the actual level of conditioning varies from place to place and because of the effect these differences are expected to have on both the drying rate and the nutritional value of the forage, it seems imperative that an objective measurement of the intensity

of conditioning be available. Such a measurement is undergoing development and evaluation in Wisconsin. A sample of the conditioned forage is washed in distilled water and the electrical conductivity of this wash water is measured. So far there appears to be good correlation between the severity of conditioning and the conductivity. Work is continuing to relate the conductivity number with increases in digestibility and increases in drying rates.

Additional, larger scale feeding trials with dairy cattle to determine the extent to which grain can be replaced by severely conditioned forage in rations while maintaining high milk production are planned in Wisconsin during 1996.

Considerations for Hay Producers

Use of intensive conditioning can accelerate forage harvesting. Hay can frequently be baled and removed from the field on the same day it is mowed. This allows the crop to immediately start regrowth. In many areas of the Southwest, this could mean one or more additional harvests per year. In addition, the fast dry-down could largely eliminate the respiration losses which continue in the plant material until the moisture content drops below 35%. The improvement in nutritional value of severely conditioned forage should allow it to command a premium price when this fact has become generally established.

It is clear that the cost of an intensive forage conditioner will be considerably greater than that of a conventional mower-conditioner. Its power requirement will also be greater. Based on the present state of knowledge it appears that both acquisition cost and power requirement may be similar to that of a forage harvester. For the producer making silage there will be some compensation, since the need for chopping will be eliminated or at least minimized. For the producer of bales, there could likewise be some compensation when baling the more compliant material, but this is less clear.

One crucial piece of the puzzle is still missing: mass-produced equipment for intensive conditioning. This will become available when the manufacturers become convinced that they can sell sufficient units to make development and marketing profitable.

REFERENCES

- Koegel, R.G., R.J. Straub, K.J. Shinnors, G.A. Broderick, and D.R. Mertens. 1992. An overview of physical treatments of Lucerne performed at Madison, Wisconsin for improving properties. *J. Agric. Engng. Res.* 51, 183-191.
- Mertens, D.R. 1993. Personal communication, USDA-ARS, Dairy Forage Research Center, Madison, WI.
- Mertens, D.R. 1995. Personal communication, USDA-ARS, Dairy Forage Research Center, Madison, WI.
- Muck, R.E., R.G. Koegel, K.J. Shinnors, and R.J. Straub. 1989. Ensilability of mat-processed alfalfa. *Proceedings 11th Intl. Congress on Agric. Engineering, Dublin.*
- Shinnors, K.J., R.G. Keogel, and R.J. Straub. 1987. Drying rates of macerated alfalfa mats. *Trans. ASAE* 30(4):909-912.
- Shinnors, K.J., R.G. Koegel, and R.J. Straub. 1988. Consolidation and compaction characteristics of macerated alfalfa used for silage production. *Trans. ASAE* 31(4):1020-1026.
- Yang, J.H., G.A. Broderick, and R.G. Keogel. 1993. Effect of heat treating alfalfa hay on chemical composition and ruminal in vitro protein degradation. *J. Dairy Sci.* 76:154-164.